

MAKE YOUR OWN GROCERY SACKS

Reduce landfill waste
Reduce use of plastics
Lower retail costs
Use your fabric
Give as gifts

Materials: $\frac{1}{2}$ yard cotton fabric (42" wide), thread

Make handles: With the fabric folded once and the selvage edges together, trim both cut edges so they are perpendicular to the fold. Cut a 3" strip from the selvage edges. (Fig 1) These two strips will form your handles. You may leave the selvages on. Fold both long edges of the handle strips $\frac{3}{4}$ " toward the wrong side and press. Fold again so the 2 folds are even with each other and press. Top-stitch along both long edges of the handles.

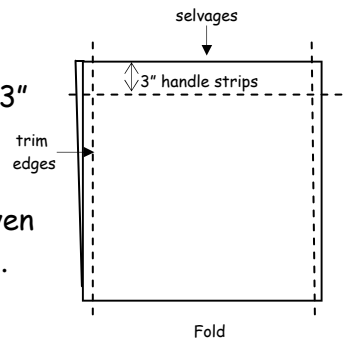

Fold

Fig 1



Fig 2

Bag: With the fabric still folded once, **wrong** sides together, stitch a narrow seam ($\frac{1}{8}$ "") down the cut edge that is opposite the fold. (Fig 3) You should now have a big tube.

Turn the tube inside out, and now with **right** sides together, sew again along the same side using a $\frac{3}{8}$ " seam allowance. This will enclose the raw edges, creating a French seam. This is a side seam and the fold is the other side of the bag.

Leave bag wrong side out. Mark 3" from the side seam and 3" from the fold along one of the raw edges. This will be the bottom of the bag. Take a 3" pleat on each side, pushing the sides in toward the center. (Fig 4) Pin the pleats.

Sew through all layers using a $\frac{1}{4}$ " seam allowance. (Fig 5) Finish the raw edge of the seam using a wide zig-zag, edge-finishing stitch, or a serger.

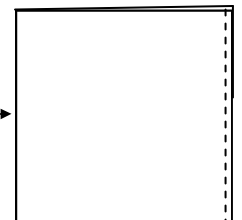

Fold

Fig 3

Fig 4

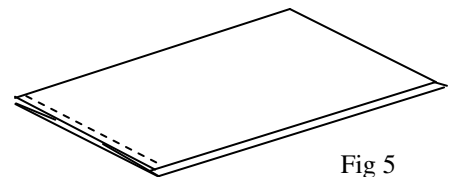
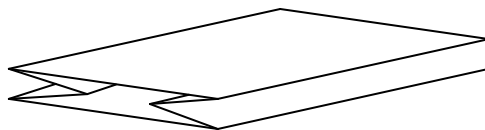

Fig 5

Top edge: With bag still wrong side out, fold top edge down $\frac{3}{4}$ " to the wrong side and press. Fold again $\frac{3}{4}$ " and press. Mark handle placement with a pin 2" from either side of the side-seam and the side-fold. Tuck one raw end of a handle under the fold, then fold the handle up and pin it to the edge of the bag. Tuck the other end under the fold at your mark which should be 4" away. Fold handle up and pin. Repeat for the other handle. Top-stitch through all layers around the edge of the bag, close to the lower edge of the fold, back-stitching across the handles to reinforce. Top-stitch again close to the upper fold, back-stitching again over the handles. (Fig 6) Turn bag right-side out. It's done. Make lots. Give them to your friends. Vow to try never to use a plastic bag again. Keep them in your car. Be sure to use them when you shop for fabric too!

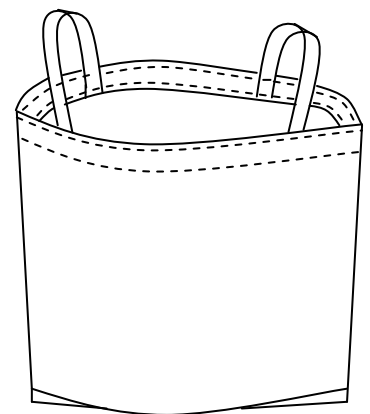

Fig 6

Karen West©2007 Special copyright notice: Quilt shops have permission to make copies of this pattern and distribute them free to customers. They do not have permission to sell this. Quilters may make copies and give them to friends.

Classes

We have lots of new classes and some popular repeats for the next three months. Look over the list carefully. Pour yourself a cup of your favorite drink, sit back and relax with your highlighter, and mark those you are interested in, so you won't miss a single one. Be sure to sign up soon, as some of our classes fill quickly. We don't want you to be disappointed. If there is a class you are looking for that is not on this schedule, let us know. We will try to schedule it if there are 4-5 people interested. This is a good way to get your friends together for a day or evening out. Please note our cancellation policy on the back page.

BEGINNER/BASICS

No quilting experience is necessary except as noted. Machine quilting classes require that you own a portable sewing machine that you will bring to class. Your machine should be in good working order and you should be familiar with your own machine's features.

Quilt School I by Machine: Learn to make a small quilt or wall-hanging from start to finish. This class is designed to introduce you to the techniques used to make beautiful quilts quickly and accurately. You will learn rotary cutting, piecing, applying borders, basting, simple machine quilting and binding. Sewing machine and basic machine sewing skills are required. (4 sessions)

Class fee: \$60

Teacher: Karen West

Date: Monday, April 21, May 5, 12, 19

Time: 10:00 a.m. - 1:00 p.m.

-or-

Monday, June 2, 9, 16, 23

6:00 p.m. - 9:00 p.m.

Hand Quilting: Learn the basic quilting stitch and how to quilt in all directions on a floor frame or in a hoop. Lots of tips from a quilter who sometimes quilts 8-10 hours a day. Bring your thimble. (1 session)

Class fee: \$20

Teacher: Sarah Porreca

Date: Thursday, May 29

Time: 10:00 a.m. - 12:00 p.m.

-or-

6:00 p.m. - 8:00 p.m.

Quilt School II by Machine: Build on the new skills you learned in QS I by taking this class specially designed to take you through the entire quilt making process again from start to finish. This lap size quilt involves slightly more intricate rotary cutting and piecing, using triangles and other designs. Prerequisite: Quilt School I taken recently. (4 sessions)

Class fee: \$60

Teacher: Diane Donovan

Date: Monday, April 21, 28, May 5, 12

Time: 6:00 p.m. - 9:00 p.m.

-or-

Monday, June 2, 9, 16, 23

10:00 a.m. - 1:00 p.m.

Beautiful Binding: Learn to finish your quilts neatly and professionally with a continuous double-fold binding. (1 session)

Class fee: \$35

Teacher: Karen West

Date: Sunday, June 29

Time: 1:00 p.m. - 4:00 p.m.

End of the Month,
End of the Bolt Sale!
On the last Saturday
of each month:

April 26, May 31, June 28

Buy whatever is left
on any bolt and get
35% off.



Beginning Sewing I: This three-part class will introduce you to your machine (any model) and get you going on two projects to help build your skills. No prior sewing experience necessary. (3 sessions)

Class fee: \$60
Teacher: Celeste Lestienne
Date: Sunday, April 27, May 4, 11
Time: 1:00 p.m. -5:00 p.m.

Beginning Sewing II (aka, not quite ready to leave the nest): If you took Beginning Sewing and would love to continue to make more great projects out of Amy Butler's book with guidance, this is the class for you. We will work on two more projects out of this book as you build more sewing confidence. (3 sessions)

Prerequisite: Beginning Sewing I
Class fee: \$50
Teacher: Celeste Lestienne
Date: Sunday, June 8, 15, 22
Time: 1:00 p.m. -4:00 p.m.

TEENS AND TWEENS

Sewing For Kids I: This class is designed for kids with little or no sewing experience. We'll learn all about the sewing machine, practice basic sewing techniques and sew five projects: a sun-glasses case, a jewelry pouch or gift bag, a pot-pourri sachet, a scrunchie and a flanged pillow. Fee includes some supplies. Ages 10 and up. Students will use store machines. (3 sessions)

Class fee: \$55
Teacher: Kristy Taylor
Date: Wednesday, April 2, 9, 16
Time: 4:00 p.m. -6:00 p.m.

Sewing For Kids II: This class will build on the sewing skills learning in Sewing For Kids I. Check back for details on what projects will be included. Ages 10 and up. Students will use store machines. (3 sessions)

Class fee: \$55
Teacher: Kristy Taylor
Date: Wednesday, April 23, 30, May 7
Time: 4:00 p.m. -6:00 p.m.

Teen Quilt Camp: Spend a week learning to quilt and knit in this combo camp. The morning will be spent in Thimble Pleasures and the afternoon at Yarns, Etc. Ages 13 and up. (5 sessions)

Class fee: \$300
Teacher: Kristy Taylor and Mary Stowe
Date: Mon-Fri, July 14-18
Time: 9:30 a.m. -4:00 p.m.



Tween Sewing Camp: Spend a week learning to sew and knit in this combo camp. The morning will be spent in Thimble Pleasures and the afternoon at Yarns, Etc. Each student will receive a a new Bernette Sewing Machine. Ages 10-13. (5 sessions)

Class fee: \$500
Teacher: Kristy Taylor and Mary Stowe
Date: Mon-Fri, July 7-11
Time: 9:30 a.m. -4:00 p.m.



ONGOING GROUPS

Basic quilting experience required. Please know your sewing machine. It should be in *good working condition*. Please call ahead even for classes that have no fee. We need to know how many are coming and there may be a supply list.

Quilters Anonymous: This is our on-going support group for all who are addicted to quilting. Bring a project you have been working on and just can't finish, or something new that you've been anxious to start. Meet new people, make new friends, laugh and have just good old fashioned fun. Entertainment provided. (on-going weekly)

Class fee: \$50 per month/\$20 per session
Teacher: Diane Donovan
Date: Every Wednesday
Time: 1:00 p.m. -3:00 p.m.

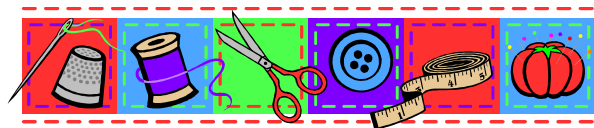

Finish-It Friday: Bring in those unfinished projects and we'll provide dinner, a knowledgeable teacher and 5 hours to get them done! If you would like to join us, but don't have a project going, Celeste will help you get started on a great quilt. (on-going monthly)

Class fee: \$35 per month
Teacher: Celeste Lestienne
Date: Friday, April 4, May 2, June 6
Time: 6:00 p.m.-11:00 p.m.

Embroider-It Friday: Experienced and newbie embroiders come stitch together for an evening and see what everyone else is working on. We will order pizza and socialize while our machines do the work!

Class fee: \$35
Teacher: Karen West and Stephanie Grant
Date: Friday, April 18, May 16, June 20
Time: 6:00 p.m.-10:00 p.m.

Stitch Lounge: This is open studio time to work on your projects in our classroom. Use our machines or bring your own. Food, drinks, and iPods are welcome. The store will be open if you need supplies. First Sunday of each month.

Class fee: \$20 per session
Date: Sunday, April 6, May 4, June 1
Time: 4:00 p.m.-8:00 p.m.

MACHINE PIECING AND QUILTING

Basic quilting experience required. Please know your sewing machine and have all supplies gathered prior to the first class. This section is now organized by date.

Goose is Loose: This classic optical illusion design is easier than it looks and will result in a stunning wall hanging or lap quilt. (2 sessions)

Class fee: \$50
Teacher: Diane Donovan
Date: Thursday, April 10, 24
Time: 6:00 p.m.- 9:00 p.m.

Working My Way Around: Take your quilting skills to a whole new level with this 6 week series. You will learn many different ways to add beautiful borders. This is a bed size quilt that will become a family heirloom. Meets every two weeks. (6 sessions)

Class fee: \$90
Teacher: Jean Wright
Date: Friday, April 11, 25, May 9, 23, June 13, 27
Time: 6:00 p.m.- 9:00 p.m.

Still Life with Fabric: You have long been admiring Susan's delightful still-life scenes in fabric. Now she will share her process with you and get you started on a whole new and easy style of quilting. You will have fun using lots of scraps and combining interesting prints and lively colors. Don't miss this! (1 session)

Class fee: \$40
Teacher: Susan Powell
Date: Friday, April 11 or Saturday, May 3
Time: 10:00 a.m.- 3:00 p.m.

Hollyhocks: This gorgeous quilt is back by popular request. If you love gardening or know someone who does, this is the one. It is especially beautiful made in many shades of batiks.

Class fee: \$40
Teacher: Sarah Porreca
Date: Saturday, April 19
Time: 10:00 a.m.-3:00 p.m.

Improvisational Art Quilts: You will design and create as you go! We will start by selecting a group of 10 or more fabrics that work together color wise, but vary in print scale and tone to create a lively and interesting combination. You will piece together your fabrics in a seemingly random and fun manner, but that will come together in a cohesive wall quilt. We will also cover some different quilting techniques as well as ways to embellish and finish your project. (3 sessions)

Class fee: \$75
Teacher: Addison Paige
Date: Wednesday, April 23, 30, May 7
Time: 6:00 p.m.- 9:00 p.m.

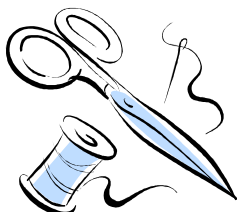

Royal Radiance: Based on Carol Doak's *Mariner's Compass Stars*. A quick, painless way to achieve perfect points! (2 sessions)

Class fee: \$50

Teacher: Diane Donovan

Date: Thursday, May 1, 15

Time: 6:00 p.m. - 9:00 p.m.

Raggedy Edge Couch Throw: Break all the rules you have just learned and throw this one together using a quick quilt-as-you-go method and all raw edges. Results in a very cuddly quilt.

(1 session)

Class fee: \$30

Teacher: Karen West

Date: Thursday, May 8

Time: 6:00 p.m. - 9:00 p.m.

Easy Pieces: This is great fun and is one of those designs that has dozens of different layouts to create unique and visually interesting wall quilts. Easy and appropriate for all levels. This filled up last quarter so don't miss this one!

(1 session)

Class fee: \$40

Teacher: Sarah Porreca

Date: Saturday, May 17

Time: 10:00 a.m. - 3:00 p.m.

3-D Fabric Vase: Ever thought of making a 3D shape with fabric? That's what we'll do using small-scale, pieced sections of fabric quilted to a heavy weight stabilizer. Then we will applique and embellish these sides before joining them together to create a standing vase. Wow! What fun, what possibilities! (3 sessions)

Class fee: \$75

Teacher: Addison Paige

Date: May 28, June 4, 11

Time: 6:00 p.m. - 9:00 p.m.

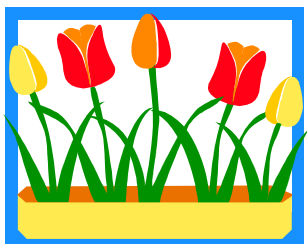

Free-Motion Quilting: This series of classes is intended to teach you how to machine quilt using free-motion. You will learn to enhance the surface of your quilt with or without the use of a pattern. Information on use of various threads and marking methods will be included.

(3 sessions)

Class fee: \$60

Teacher: Celeste Lestienne and
Stephanie Pennington-Grant

Date: Thursday, June 5, 12, Tuesday
June 24 -or-

Tuesday, June 10, 17, 24

Time: 6:00 p.m. - 9:00 p.m.

Landscape: Back by popular request! Learn to make a beautiful landscape scene by using Gail's simple curved piecing techniques. (1 session)

Class fee: \$35

Teacher: Gail Green

Date: Saturday, June 14

Time: 10:00 a.m. - 1:00 p.m.

Curved Strip Piecing: Expand your curved piecing skills with this small wall hanging that is perfect for embellishing. (1 session)

Class fee: \$35

Teacher: Gail Green

Date: Saturday, June 14

Time: 2:00 p.m. - 5:00 p.m.

Melons: This classic curved block is easily made using rotary-cut templates. This is a block that has endless design possibilities once you know how to piece it. (2 sessions)

Class fee: \$50

Teacher: Stephanie Pennington-Grant

Date: Thursday, June 19, 26

Time: 6:00 p.m. - 9:00 p.m.

Ohio Star: This is a classic traditional design that can be made into a lap quilt, or make more blocks and make a bed size quilt. (1 session)

Class fee: \$40

Teacher: Sarah Porreca

Date: Saturday, June 21

Time: 10:00 a.m. - 3:00 p.m.



CRAFTS AND OTHER SPECIALTIES

Pouch Double-Header: If you like to organize your stuff, you will love these little zipper pouches. Quick, extremely easy and re-sizeable, they make excellent and inexpensive gifts for any occasion. You will learn to make two different types of pouches in this class. (1 session)

Class fee: \$40
Teacher: Karen West
Date: Sunday, May 18
Time: 1:00 p.m. - 5:00 p.m.

Japanese Temari: Learn this traditional craft and create small works of art by stitching intriguing designs onto a thread-wrapped ball. Taught by local temari expert and author, Barb Suess. For more information visit Barb's website, www.japanesetemari.com. (3 sessions)
Kit fee.

Class fee: \$50
Teacher: Barb Suess
Date: Tuesday, April 15, 22, 29
Time: 2:00 p.m. - 4:00 p.m.

Intermediate Japanese Temari: Expand your temari stitching skills by learning to stitch a more intricate design. (1 session)

Class fee: \$30
Teacher: Barb Suess
Date: Tuesday, May 6
Time: 2:00 p.m. - 4:00 p.m.

COMPUTER CLASSES:

Artista Software Mastery:* Open to all Bernina Software owners of Editor, Auto Designer and Designer Plus. This series of training classes is designed to help you feel more comfortable using your embroidery design software for altering, creating and digitizing your designs. Laptops or PC's are required. Sewing machines not needed in class. (4 sessions)

Teacher: Jane Stein
Date: Sunday, March 30, April 6, 13, 20
Time: 1:00 p.m. - 4:00 p.m.

Electric Quilt 6 Basics: EQ6 is a powerful software program that allows you to see your quilts on screen before you make them. If you are already an EQ5 user, the upgrade to Version 6 is available now. If you are new to EQ, this series will help you get started and get the most out of a great tool for all quilters. Software and laptop required. (3 sessions)

Class fee: \$50
Teacher: Karen West
Date: Sunday, June 8, 15, 22
Time: 6:00 p.m. - 8:00 p.m.

BERNINA MACHINE MASTERY:

This is a series of classes offered to Bernina owners that are on-going and will help you become more familiar and comfortable using your new machine. Please note that session #1 is repeated the first week of each month. (4-8 sessions)

Teacher: Celeste Lestienne
Date: Tuesday, April 1, 8, 15, 22, 29,
May 6, 13, 27, June 3
Time: 10:00 a.m. - 1:00 p.m.
-or-
6:00 p.m. - 9:00 p.m.

EMBROIDERY MASTERY:

Open to all Bernina embroidery module owners. A comprehensive class to learn how to set up your machine to embroider. Includes preparing your design, hooping, stabilizers, threads and stitching-out. (3 sessions)

Teacher: Celeste Lestienne
Date: Saturday, April 12, May 10,
June 7
Time: 10:00 a.m. - 3:00 p.m.

SERGER MASTERY:

For all new Bernina Serger owners. Learn to thread and use your new serger. (5 sessions)

Teacher: Celeste Lestienne
Date: Friday, April 25, May 2, 9,
16, 23
Time: 10:00 a.m. - 12:00 p.m.



Class Registration and Cancellation Policy:

Either stop by the store to register, call in to register by credit card, or mail in this form with a check. Full amount of the class must be paid upon registration. Cancellation by students requires 7 or more days notice; otherwise, your fee will be forfeited. If classes are cancelled because the minimum enrollment has not been met, you will receive a full refund. We consider your enrollment to be your commitment to take the class. We then make a commitment to our teachers. A class supply list will be handed or mailed out when you register. Please do not purchase your supplies until you have confirmed that the class will go ahead as scheduled. A 10% DISCOUNT IS OFFERED TO OUR STUDENTS FOR ALL SUPPLIES PURCHASED FOR YOUR CLASS. WE CARRY ONLY QUALITY FABRICS AND SUPPLIES AND APPRECIATE YOUR SUPPORT.

Name _____			
Address _____			
City _____	State _____	Zip _____	
Phone _____	Email _____		
Class Title _____	Date _____	Time _____	Cost _____

Method of Payment: <input type="checkbox"/> Check enclosed			
Credit Card # _____	Exp. Date _____		
Signature _____			

Thimble Pleasures
205 West Main Street
Carrboro, NC 27510
919-968-6050

**HOURS: Mon-Fri 10-6
Sat 10-5
Sun 1-4**